

**Selbstentlader Gattung Fals 185.1 der DB, Ep V:**

eerste bouwserie

/

erste Baulos

Bouwhandleiding

MOSPAT Kit

Bauanleitung



1/1



1/43.5

## Tooling



### Legende:

Schruppen /schleifen	=	A	=	Afbramen & opschuren
Bohren Durchmesser	=	B /	=	Boren / diameter
Feilen / Form	=	F /	=	Vijlen / vorm
Kleben	=	K	=	Kleven, lijmen met secundelijm
Schneiden	=	S	=	Snijden
Montieren	=	M	=	Monteren
Grundieren/ontvetten	=	Pk	=	Primer kunststof & ontvetten
Grundierung	=	Pa	=	Primer /grondverf
Farbanstrich lt RAL	=	V	=	Verven in RAL kleur
Beschriftung	=	L	=	Lettering, cijfers en beschrifting
Schrauben	=	F	=	Schroeven
Umbiegen auf Maß	=	U	=	Plooien op maat
Klarlack	=	C	=	Matvernislaag

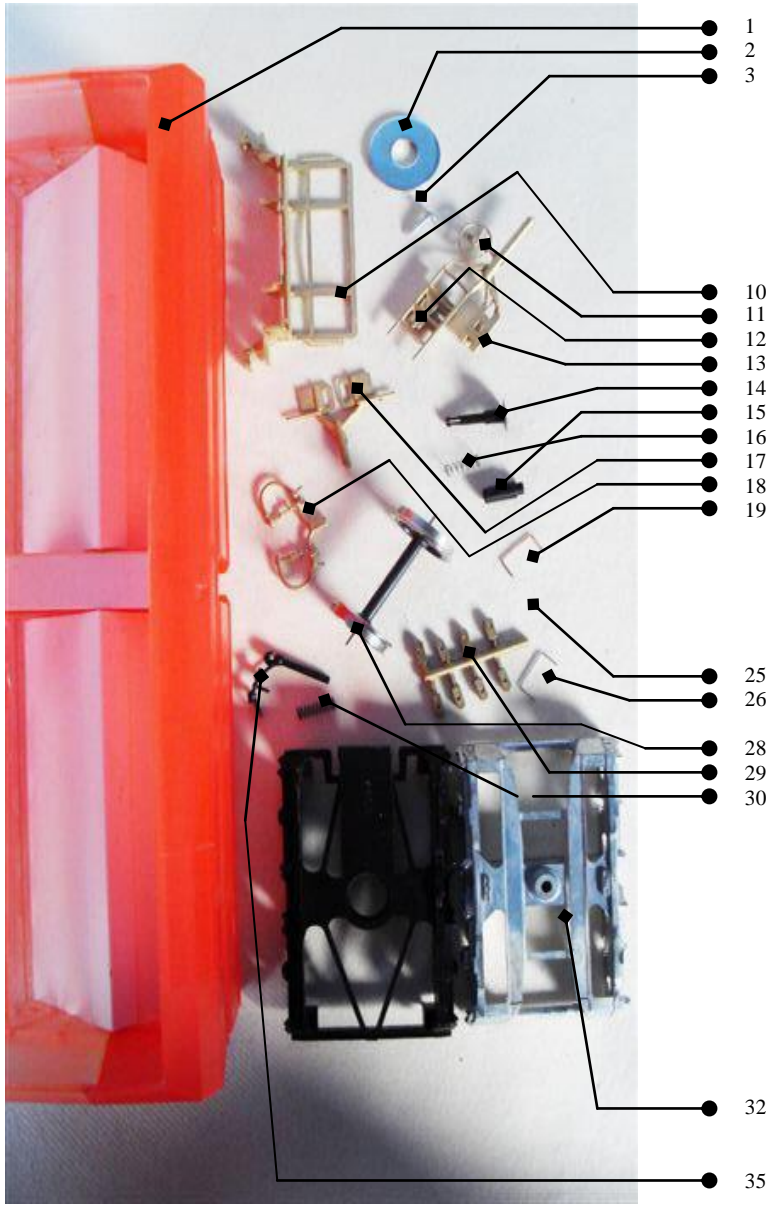

Onderdelenlijst	St / St	Teilen Bezeichnung
1) wagen koetswerk	(1x)	Gehäuse
2) draaistelring	(2x)	Unterlegscheibe Drehgestel
3) schroef voor draaistel	(2x)	Schraube für Drehgestel
4)		
5)		
6)		
7)		
8)		
9)		
10) platform	(2x)	Rangierbühne
11) handwiel	(2x)	Handrad
12) last en remschakelaar	(2x)	Last und Bremsschalter
13) koppelingsmond	(2x)	Kupplungsmund
14) bufferstift	(4x)	Pufferstift
15) bufferhuls	(4x)	Pufferhülse
16) bufferveer	(4x)	Pufferfeder
17) trekogen	(4x)	Seilösen
18) remslang	(2x)	Bremsschlauch
19) handgreep	(4x)	Handgriffe
20)		
21)		
22)		
23)		
24)		
25) splitpen voor koppeling	(2x)	Splinte für Kupplung
26) rangeerhandgreep	(4x)	Rangiergriffe
27)		
28) wielstel	(4x)	Radsatz
29) wielstelloopbus	(8x)	Radsatzgleitlager
30) koppelingsveer	(2x)	Kupplungsfeder
31)		
32) draaistel 661	(2x)	Drehgestell 661
33)		
34)		
35) schroefkoppeling	(2x)	Schraubekupplung

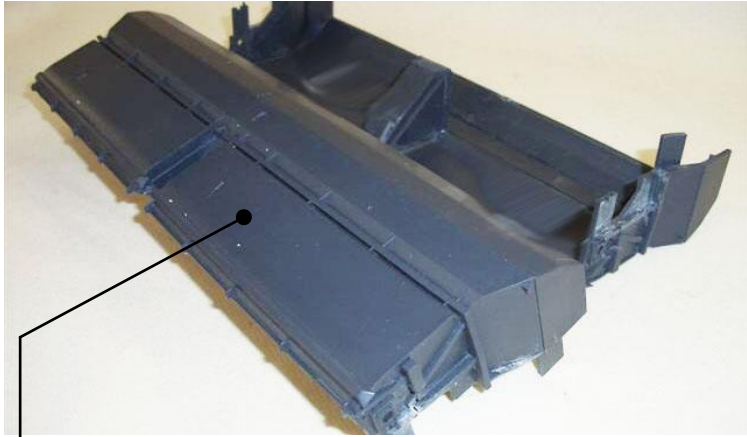

A: afbramen & opschuren / *Schruppen & schleifen*

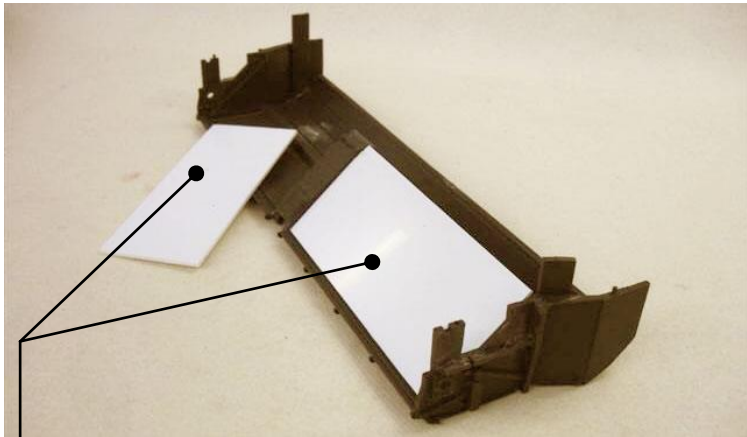

K: van de stortvlakken / *Rutsche an jede Innenseite*

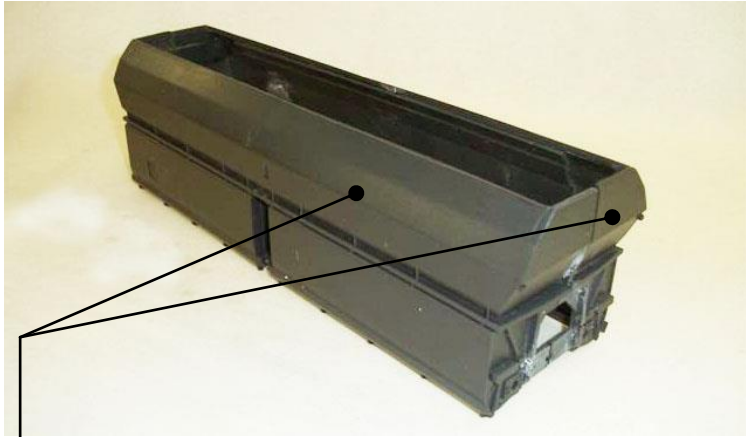

● K: beide wagenhelften tegen elkaar / *Wagenseiten atf einander.*

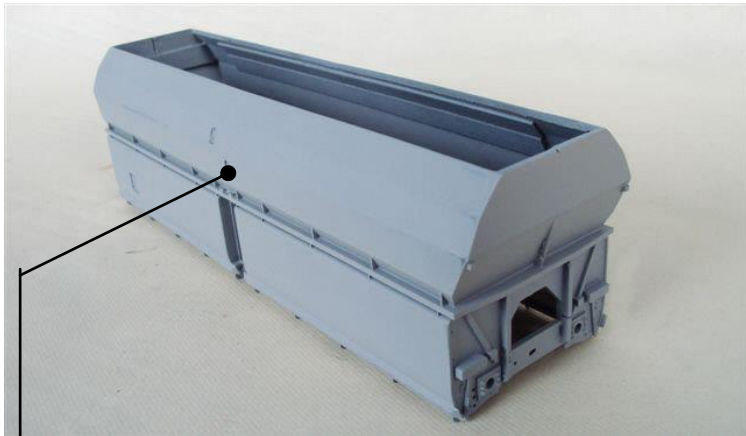

● Pk: ontvetten & grondlaag voor kunststof / *Entfetten & Grundierung für Kunststoff*

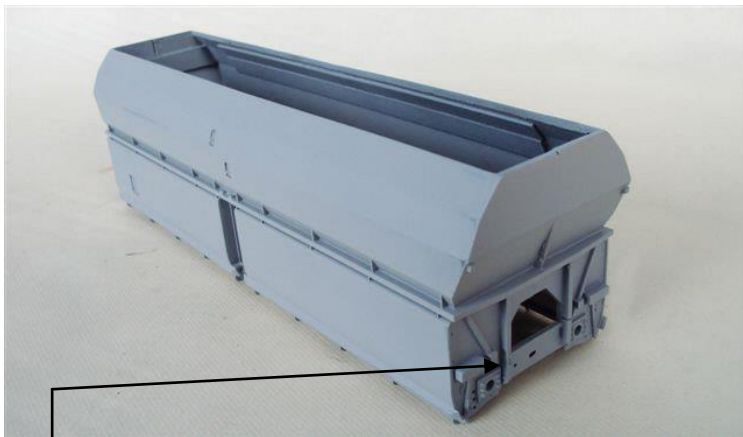

● B/ diam 1.3 mm: 1x remslang (x2) / 1x *Bremsschlauch* (x2)

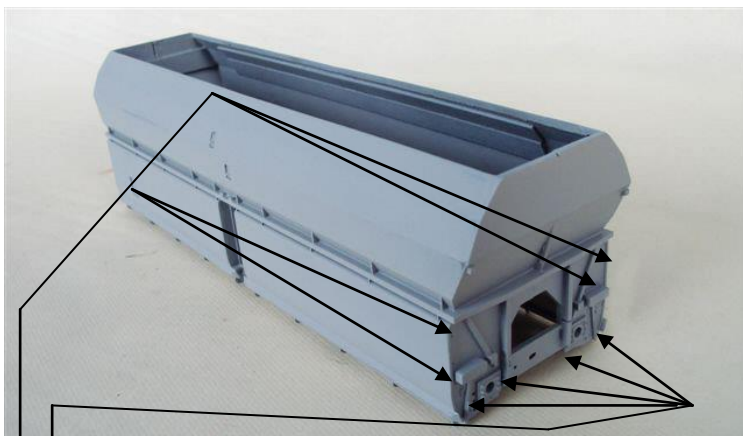

● B/ diam 1,0 mm: 2x rangeergreep (x2) / 2x *Rangiergriffe*(x2)  
● B/ diam 1,0 mm: 2x rangeergreep (x2) / 2x *Rangiergriffe*(x2)

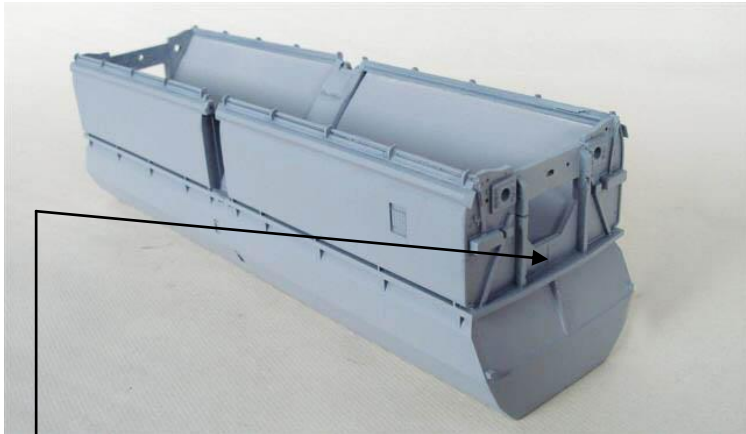

- B/ diam 1,0 mm: 1x klephandwiel (x2) / 2x Handrad (x2)

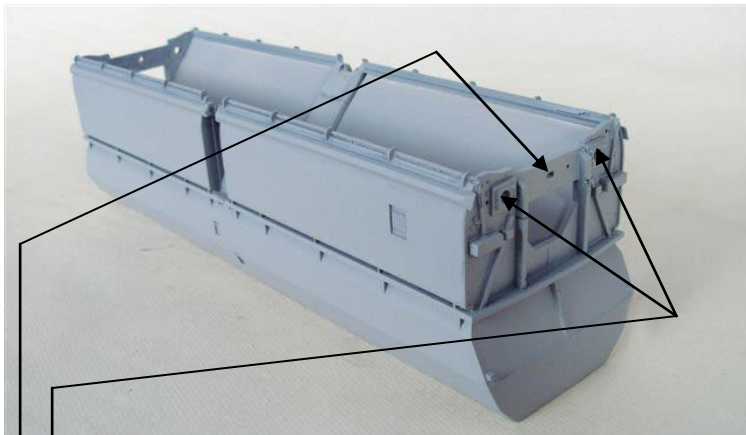

- B/ diam. 3,6 mm: 2x bufferopening (x2) / 2x Pufferloch (x2)
- F/ vierk. 2x2 mm: 1x koppelopening (x2) / 1x Kupplungsloch (x2)



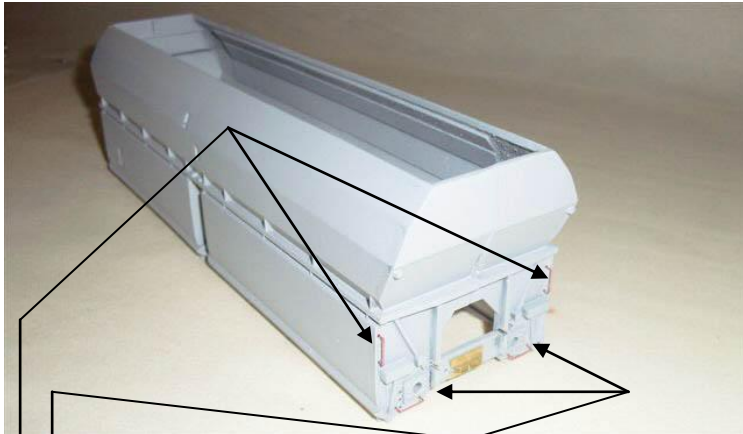

- K: 2x rangeergrepen (x2) / 2x Rangiergriffe (x2)
- K: 1x korte handgreep (x2) / 1x kurze Handgriffe (x2)



- K: 1x koppelingsmond (x2) / 1x Kupplungsmund (x2)

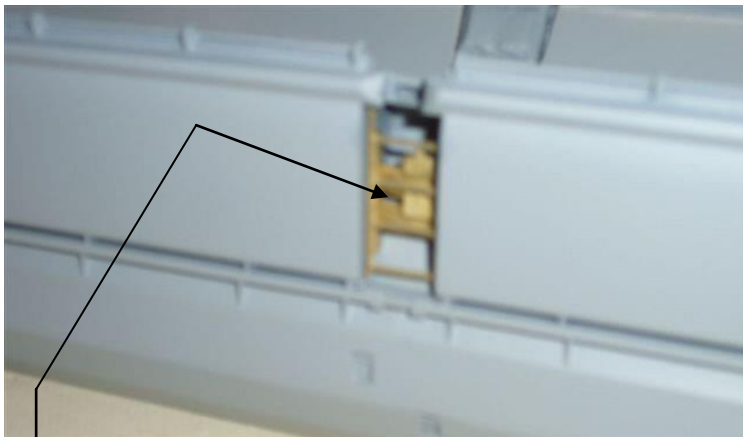

● K: 1x remslang (x2) / 1 x *Bremsschlauch* (x2)

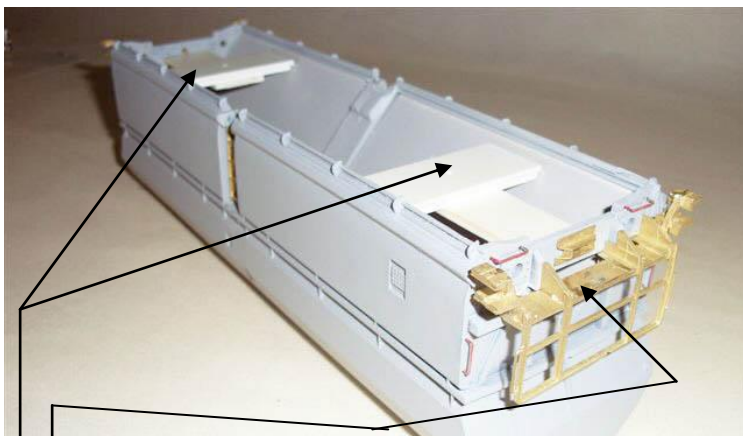

● K: 1x platform (x2) / 1x *Rangiebühne* (x2)  
 ● K: 2x draaistelsteun (x2) / 2x *Drehgestellhaltung* (x2)

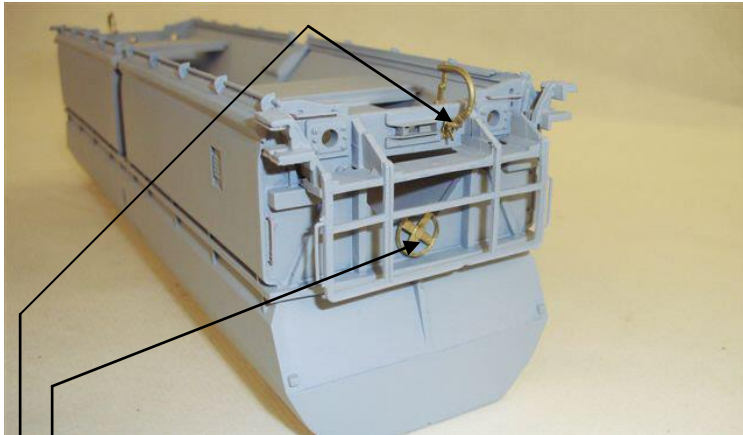

- K: 1x handwiel (x2) / 1x Handrad (x2)
- K: 1x remslang (x2) / 1x Bremsschlauch (x2)

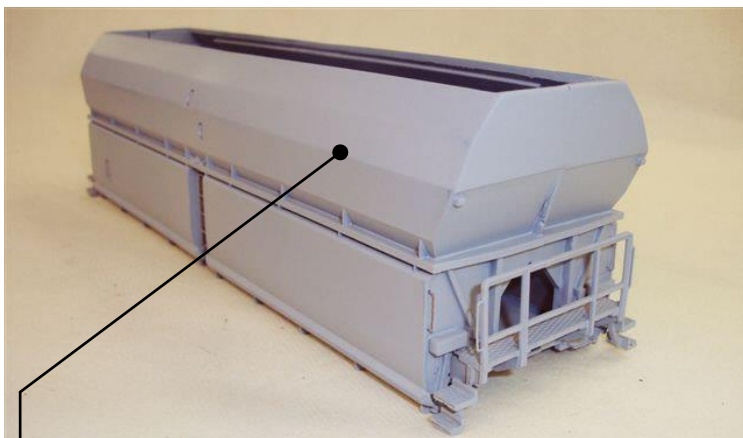

- Pa: algemene grondlaag / allgemeine Grundierung

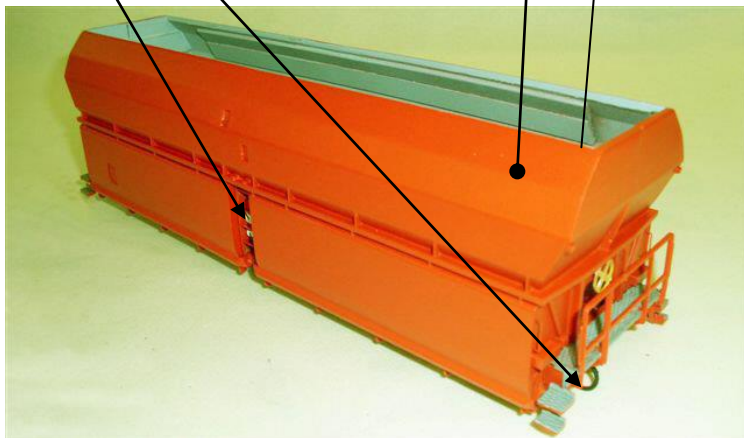
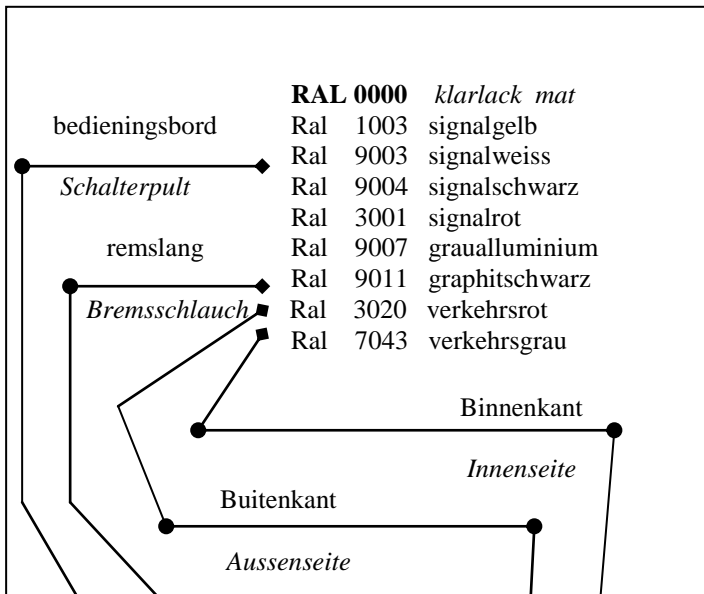

V

**RAL 0000** klarlack mat

- Ral 1003 signalgelb
- Ral 9003 signalweiss
- Ral 9004 signalschwarz
- Ral 3001 signalrot
- Ral 9007 graualluminium
- Ral 9011 graphitschwarz
- Ral 5017 verkehrsblau
- Ral 7024 graphitgrau

handgrepen  
*Handgriffe*

Handwiel  
*Handrad*

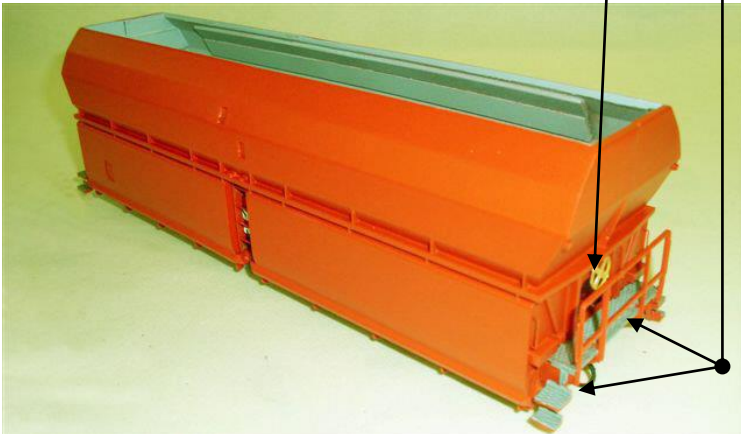

V

**RAL 0000** klarlack mat

Ral 1003 signalgelb

Ral 9003 signalweiss

Ral 9004 signalschwarz

Ral 3001 signalrot

Ral 9007 graualluminium

Ral 9011 graphitschwarz

Ral 5017 verkehrsblau

Ral 7024 graphitgrau

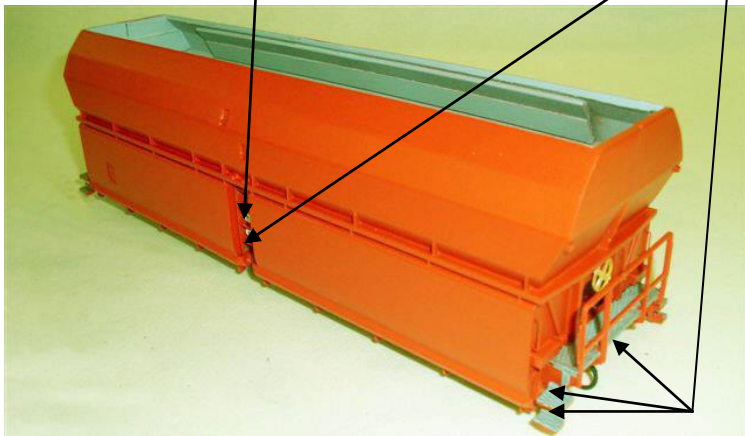
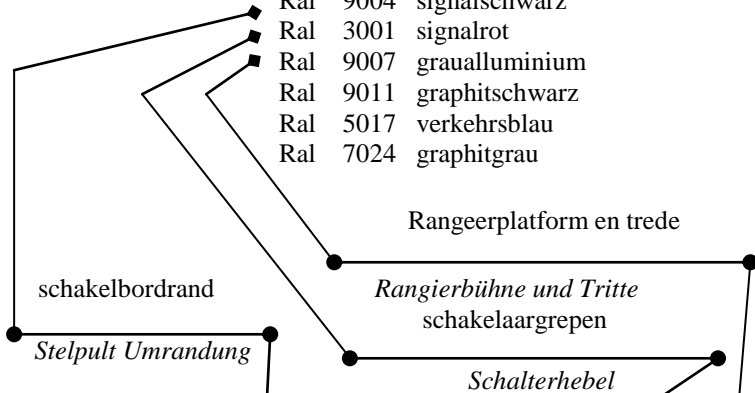

V



L: Fals 185.1



L: Fals 185.1

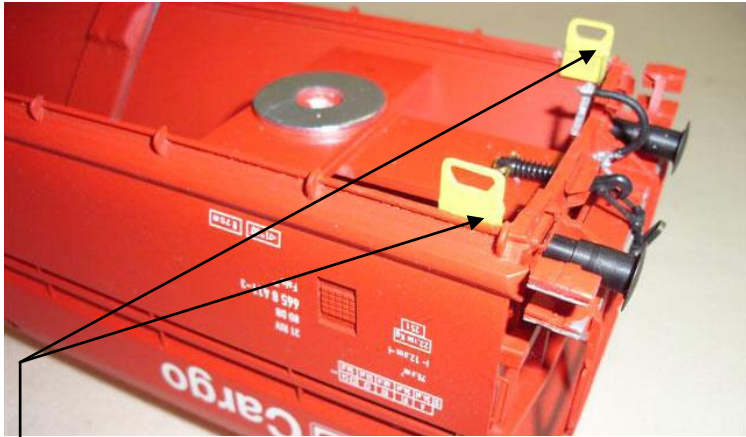

● K: 2x rangeerogen (x2) / 2x Rangierösen (x4)

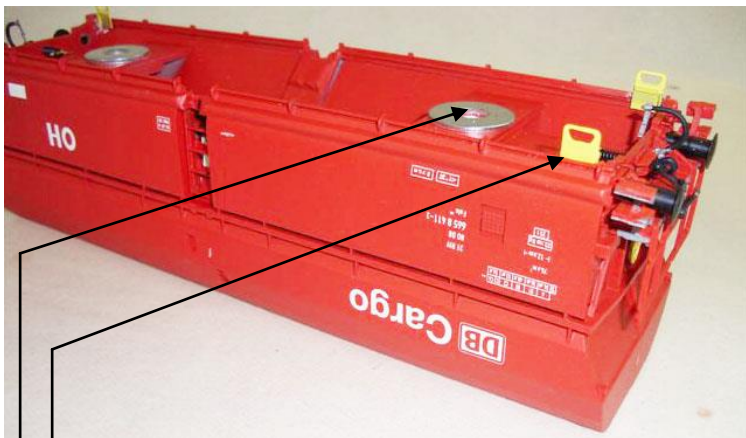

● M: koppeling /veer /splitpen (x2) / Kupplung/ Feder/ Splinthe  
 ● K : 1x draaistelring (x2) / 1x Unterlegscheibe (x2)



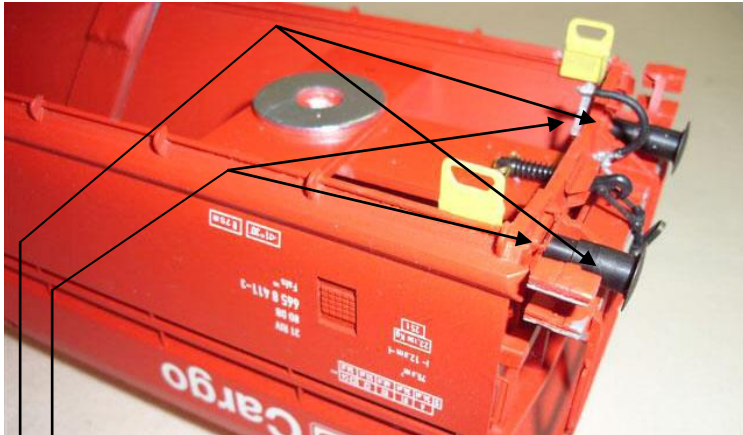

- M: 2x bufferstift met veer (x2) / 2x *Pufferstift mit Feder* (x2)
- M: 2x bufferstiftmin huls (x4) / 2x *Pufferstift in Hülze* (x4)

**Werkwijze draaistellen 661 / *Arbeitsgang für Drehgestelle 661***

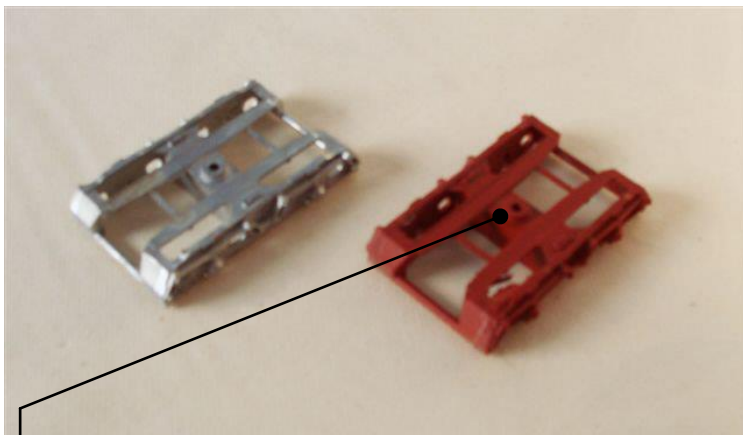

- Pa: algemene grondlaag (x2) / *allgemeine Grundierung* (x2)

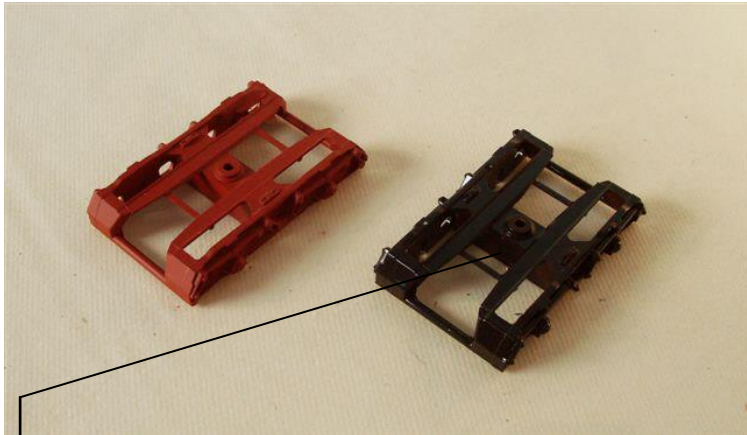

● V: Ral 9011 graphitschwarz



● A & B/ diam 1.5 mm: 8x glijlager / 8x Gleitlager

**Kraag buitenzijde onder / Bunte am Aussenseite Unten**

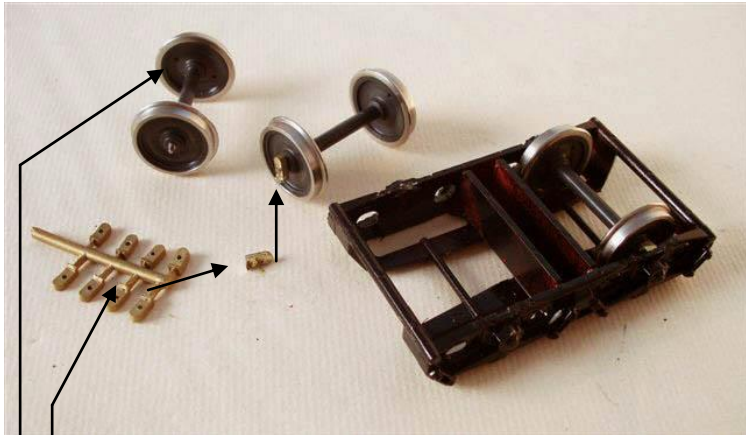

- M: 2 x loopbus per as (x2x2) / 2xLaufbuchse pro Achse (x2x2)
- M: 2 x wielstel per draaistel (x2)/ 2 xRadsatz pro Drehgestel (x2)



- M: draaistel met grote schroef / Drehgestelle mit große Schraube



C: Mat vernislaag

/ Klarlack schicht



*Ready to Run*

*Fals 185.2 DB Ep V / tweede bouwserie / zweite Bauolos*



Fals 185.2

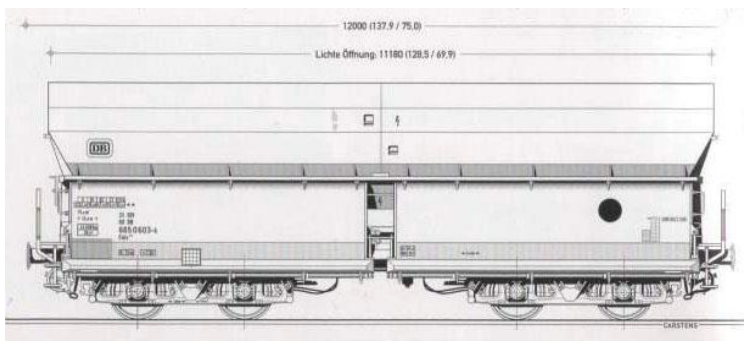

Fals 185.2



- Trekhaken / Seilhaken
- versterkte klepranden / versterkte Klappenseiten
- andere documentenhouder / geänderte Zettelhalter



***Ready to Run***